

ReelGreen RG25

Instruction Manual For Operation and Maintenance



BIGsprinkler.com

BigSprinkler.com
15250 Sunshine Rd.
Yukon, OK. 73099
800-373-9325

Introduction

Thank you for purchasing a ReelGreen RG25 traveling sprinkler system. Please read this manual carefully before operation in order to become familiar with all components and their function. Safety is the main priority and failure to follow these instructions may cause serious injury. Neither ReelGreen nor BigSprinkler.com are to be responsible for machine failure or personal injury if these procedures and operation instructions are not followed.



Caution



- **Do not operate your ReelGreen traveler without a serious overview of this manual**
- **Keep children and unauthorized people away from traveler**
- **Never allow children access to use the traveler**



- **Use caution when disconnecting couplings**
When the traveler shut-off valve activates, the supply hose remains pressurized at the end of the run. First, relieve the pressure with the relief valve, then disconnect the supply hose.
- **Use caution with the sprinkler heads**
Pressurized water from the sprinkler head could cause serious damage to people or objects.
- **Use caution during transport**
Travelers are not made for public transit. Do not exceed 7mph on flat roads, or 2 mph on steep inclines.
- **Never service the traveler when it is in operation**
Before servicing, stop the traveler and disconnect the supply line. All safety guards and shields must be in place while operating the traveler.
- **Beware of power lines**
Irrigation water should never contact power lines or any other power source. Never let any part of the traveler or any irrigation pipe get in contact with power source.

Identification Data

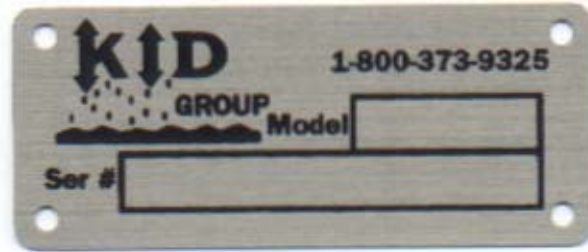

The identification plate includes the model and serial number for your machine.

Machine Controls & Components

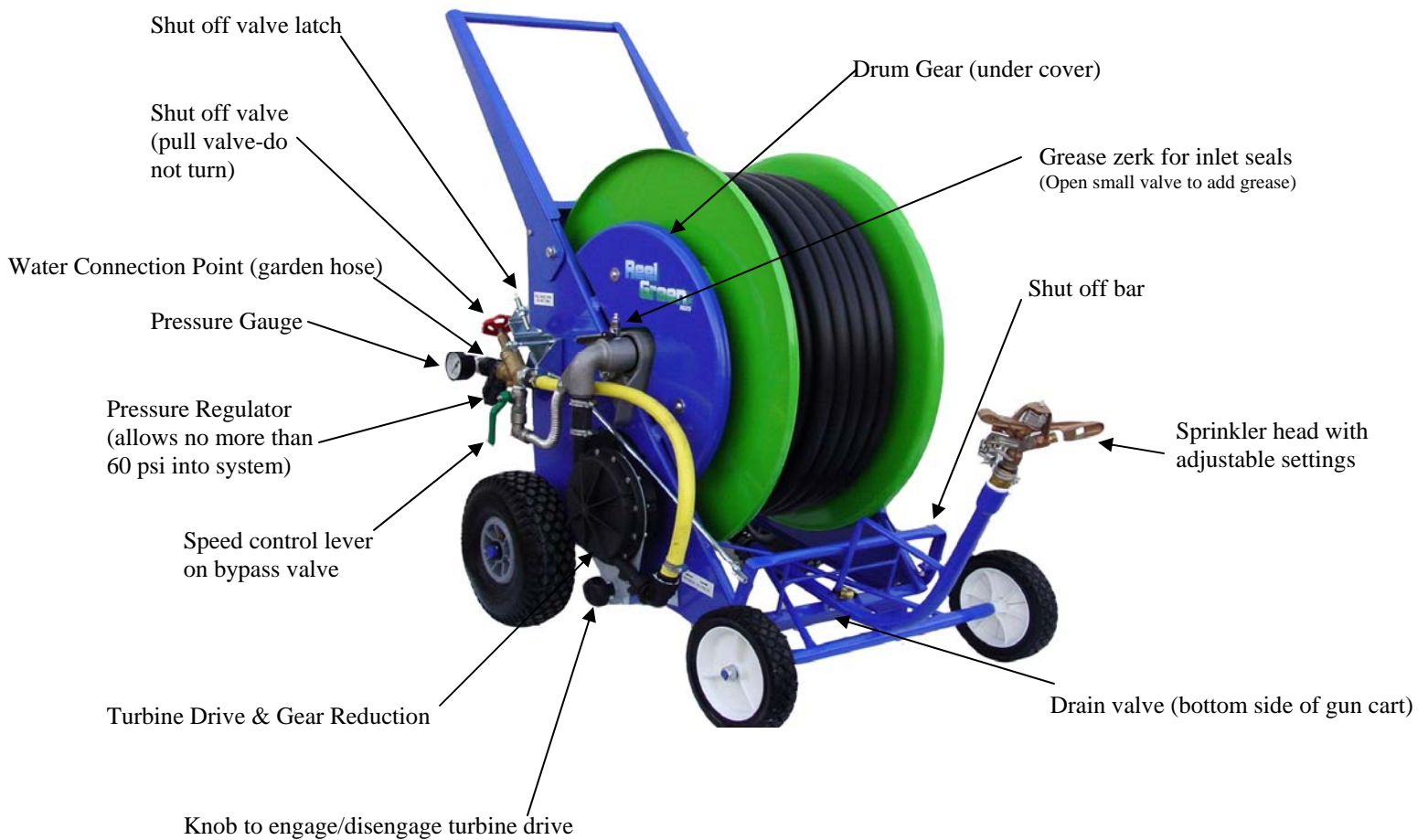

Conditions For Machine Operation

The RG25 is designed for clean water suitable for irrigation. The machine is not designed for water that includes large pieces of debris or slurry/wastewater conditions.

Start Up Procedure/Operation



1) Push the machine to the desired location. Position the machine with the sprinkler cart facing the direction to be irrigated. Insure that the machine is sitting level in order for the tube to wrap properly.



2) Loosen the black turbine lock knob as shown at the bottom of the image to the left by turning counter-clockwise. Now the turbine drive assembly and bracket will slide towards the sprinkler cart (as shown by white arrow) to disengage the turbine drive gears. Re-tighten the knob to hold the turbine drive gear away from the drum gear. Drum will now spin freely allowing sprinkler cart to be pulled out.



3) Sprinkler cart may now be pulled out by hand.

IMPORTANT: Pull the sprinkler cart out in a straight line from the machine to allow the tube to wrap back onto the drum straight. Never make sharp turns with the polyethylene hose and always leave one or two wraps on the drum to keep from pulling the tube off of the drum.

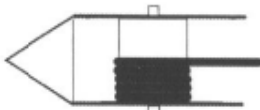

Keep remaining wraps tight!!

4) Proceed back to the drum and tighten the few loose coils that are left on the drum by hand. This will ensure that the coils start wrapping in the correct manner when the drum starts turning.

Start Up Procedure/Operation, continued

****IMPORTANT: ALWAYS PULL CART OUT STRAIGHT AND TIGHTEN LOOSE WRAPS BEFORE START UP!**

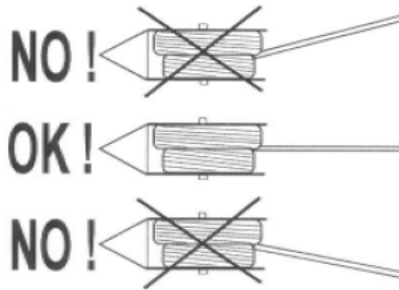

Always Pull Tube Out Straight!

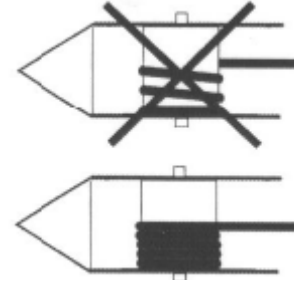

Keep Wraps Tight!



5) Re-engage the turbine assembly by loosening the black knob again and sliding the turbine bracket back into place as shown by white arrow, so that the drive gears mesh. Tighten the black lock knob again to hold the turbine in place.

IMPORTANT: Before proceeding, try turning the drum by hand to make sure it is locked in gear. It should be locked and will not turn.



6) Open shut off valve by pulling the valve handle and latching into the open position by swinging the valve latch down and into position to hold valve open as shown.

IMPORTANT: PULL VALVE, DO NOT TURN!

NOTE: DO NOT PULL VALVE OPEN UNDER PRESSURE. OPENING UNDER PRESSURE WILL DAMAGE VALVE!



VALVE SHOWN IN OPEN, LATCHED POSITION



7) Attach supply hose provided to the inlet of the machine and lock into place as shown

IMPORTANT: MAKE SURE SUPPLY HOSE IS CLEAN AND FREE OF FOREIGN OBJECTS THAT WOULD PLUG THE TURBINE SYSTEM OR SHUT OFF VALVE! INLET CONNECTION IS FITTED WITH A DEBRIS STRAINER THAT MAY NEED TO BE CHECKED FROM TIME TO TIME AND CLEANED IF FOREIGN OBJECTS OR MATERIAL ARE PRESENT IN INCOMING WATER.

Start Up Procedure/Operation, continued



8) Turn on the water source to the RG25. The sprinkler equipped with the RG25 can be set to water a full circle pattern or any part of a circle. It is generally recommended to water a half circle pattern behind the cart, away from the direction of travel. The RG25 is equipped with a pressure regulator at the inlet to maintain system pressure at no more than 60 psi.

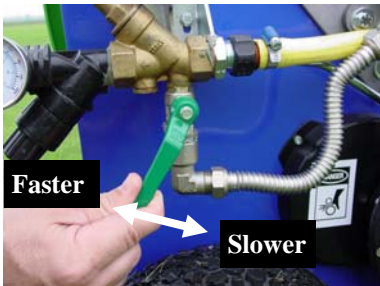

9) Adjust the speed of cart retraction by moving the bypass lever or speed control lever in the directions shown by the arrow. Closing this valve will increase retraction speed and opening the bypass valve will slow down the retraction speed



10) Once the speed is set, the RG25 will automatically roll the tube on the drum and stop at the end of the run utilizing the shut off valve.

IMPORTANT: Your RG25 traveler operates between 3 and 11 gallons per minute. This is regulated by changing the sprinkler nozzle to match your water source's capability. The smallest nozzle is installed in the sprinkler from the factory. If you have a good water source with adequate pressure, it is possible to increase to a larger nozzle size if needed. Consult your application chart or call 800-373-9325 for more information.

Troubleshooting

1) PROBLEM: NO WATER AT THE SPRINKLER

SOLUTION: 1. Make sure shut off valve is open.
2. Potential blockage—clean inlet screen/sprinkler nozzle.

2) PROBLEM: MACHINE WILL NOT ROLL UP

SOLUTION: 1. Make sure turbine is in the engaged or run position as shown in start up steps.
2. Turbine bypass valve (speed control valve) is opened too far. Close valve to increase speed.
3. Not enough pressure to initiate turbine drive.
4. Debris in inlet filter screen not allowing flow into the machine.

3) PROBLEM: MACHINE STOPPED DURING RETRACTION

SOLUTION: 1. Water flow stopped or was lowered during retraction, causing the turbine to stall. Simply turn the bypass valve closed to start retraction once again and adjust speed as needed.
2. Clean debris from inlet filter screen

Winterization

1. Disconnect Supply Hose.
2. Open and leave shut off valve in run position as shown by yellow arrow.
3. Speed control valve must be positioned as shown by red arrow.
4. Disconnect yellow turbine entry hose as shown by the blue arrow.
5. Drain guncart by removing plug located on the underneath side of the cart as shown in the image below.
6. An air blow out fitting may also be ordered to air purge the system when winterizing if you have an air compressor. When using the blow out fitting and air compressor, perform steps 1, 2, and 3, and connect the air blow out fitting where the supply hose normally attaches to the inlet of the machine. Connect your air hose to the fitting and slowly open the valve on the blow out fitting and water will exit the sprinkler head. Continue until all water is purged and air begins to appear at the sprinkler head. Your system will be ready to store for winter.

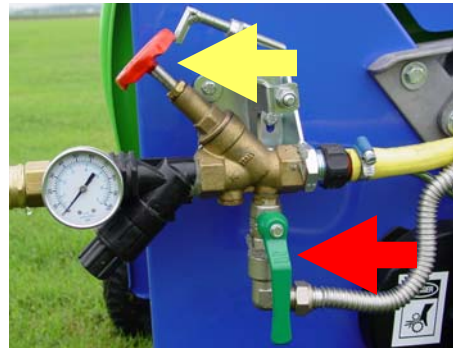

Guncart drain location on RG25

Options



RG25 Air Blow Out Fitting

For use with air compressor to winterize machine.



RG25 Depth Control Plate

Keeps front of machine level and supported in loose soil conditions.



RG25 Boost Pump Option

110v Booster kits to boost incoming pressures by 30 to 50 psi.

Gas driven booster kits also available.

Contact us at 800-373-9325 for details or visit www.bigsprinkler.com

Maintenance Schedule

Inlet seals: Grease inlet seals every 100 hours.

Drum gear: Grease drum gear every 100 hours.

Turbine Seals: Replace turbine seals every 500 hours or once a season. Consult your dealer for information.

Performance Chart

RG25 PERFORMANCE CHART

4 mm Nozzle

INLET PSI	GPM	80%		RUN TIME(HRS)		
		MAX WIDTH ADJ	WIDTH	MAX LENGTH	0.10 INCH	0.25 INCH
35	3.2	72	58	201	3.10	7.74
50	4	79	63	204	2.69	6.73
60	4.5	86	69	207	2.62	6.55

5 mm Nozzle

INLET PSI	GPM	80%		RUN TIME(HRS)		
		MAX WIDTH ADJ	WIDTH	MAX LENGTH	0.10 INCH	0.25 INCH
40	5.3	79	63	204	2.03	5.08
50	5.9	86	69	207	2.00	4.99
60	7	92	74	211	1.81	4.51

6 mm Nozzle

INLET PSI	GPM	80%		RUN TIME(HRS)			
		MAX WIDTH ADJ	WIDTH	MAX LENGTH	0.10 INCH	0.25 INCH	0.50 INCH
45	7.4	86	69	207	1.59	3.98	7.96
55	8.5	92	74	211	1.49	3.72	7.44
60	9.2	95	76	213	1.41	3.53	7.06

Parts Diagrams

DRUM

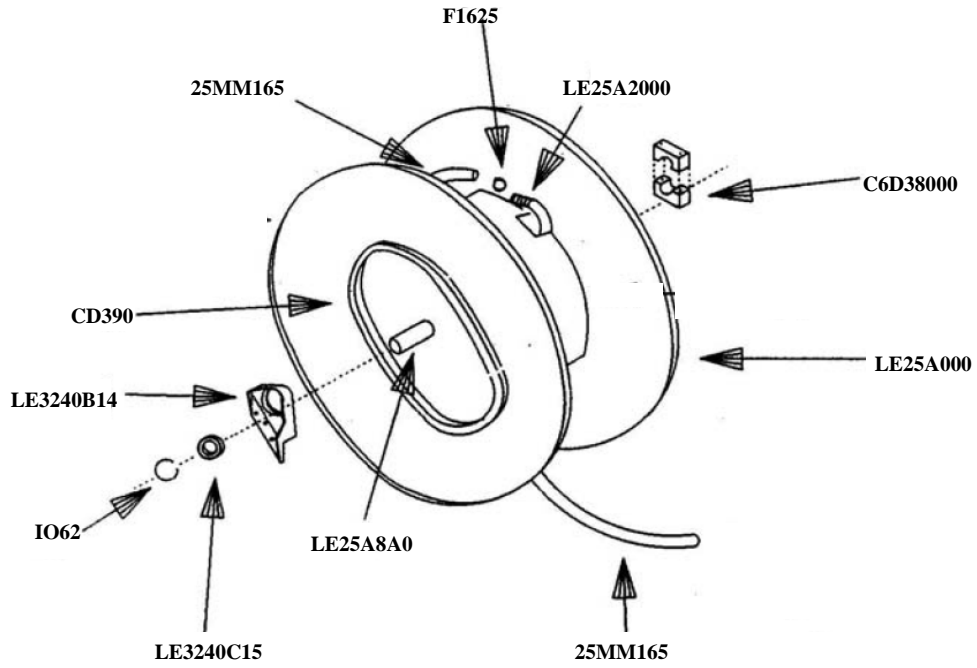

Frame/Chassis

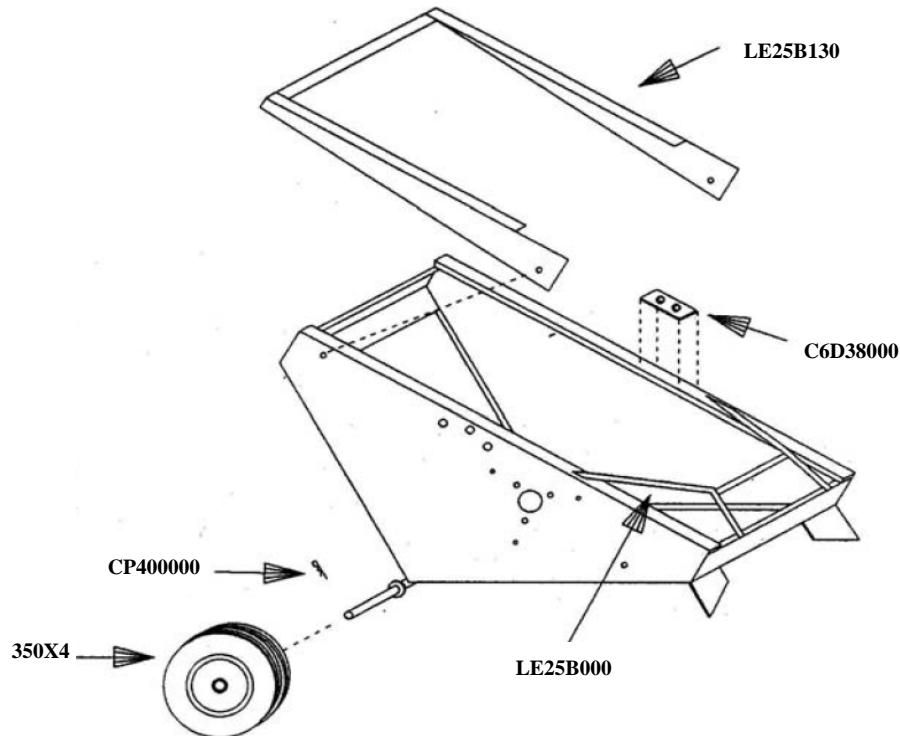

Parts Diagrams

Drive System

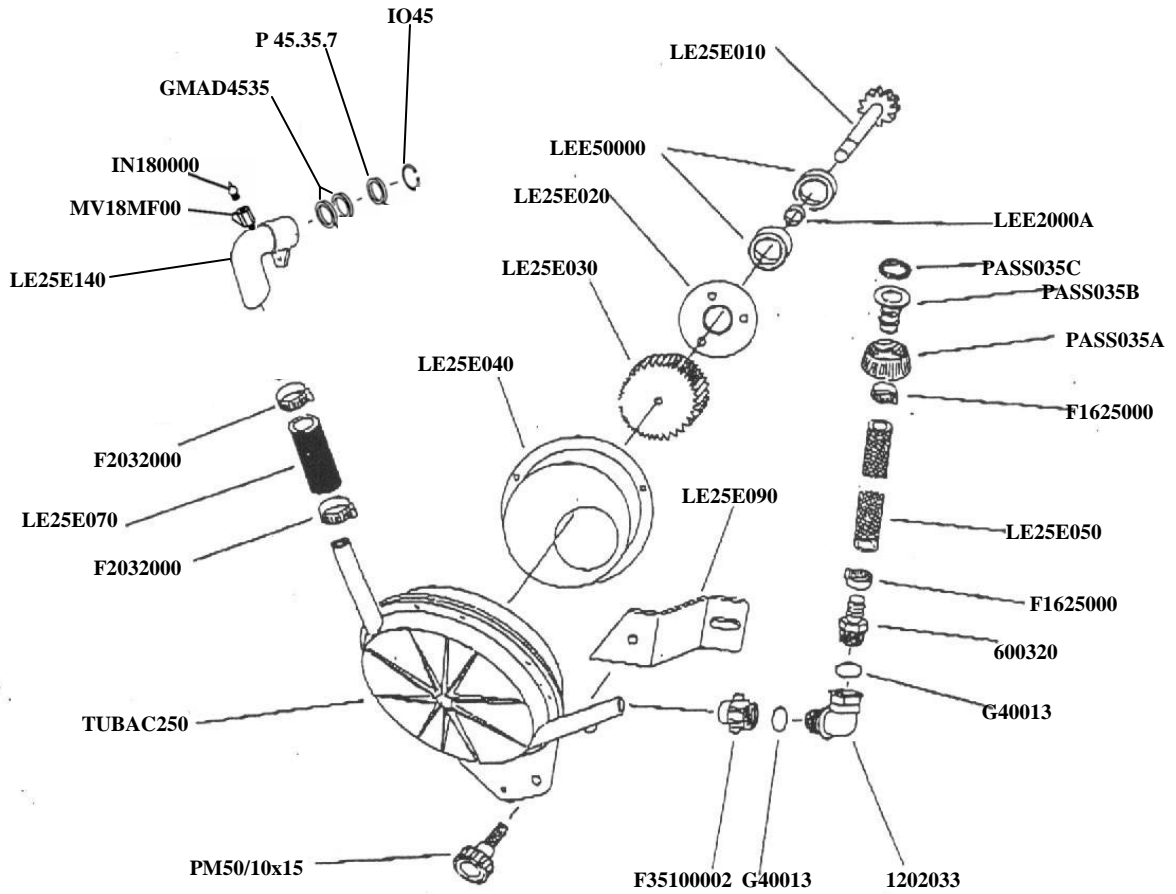

BA026027P2 (Standard Speed Drive Gear-not shown)

BA026027L25 (High Speed Drive Gear-not shown)

Sprinkler Cart

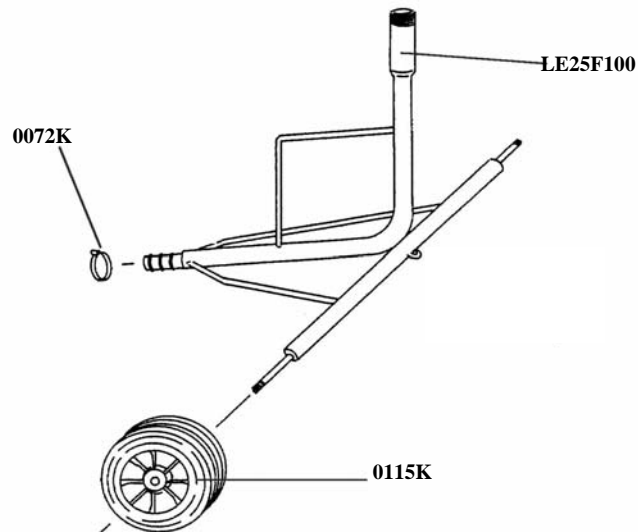

Parts Diagrams

Shut Off /Speed Control Assy.

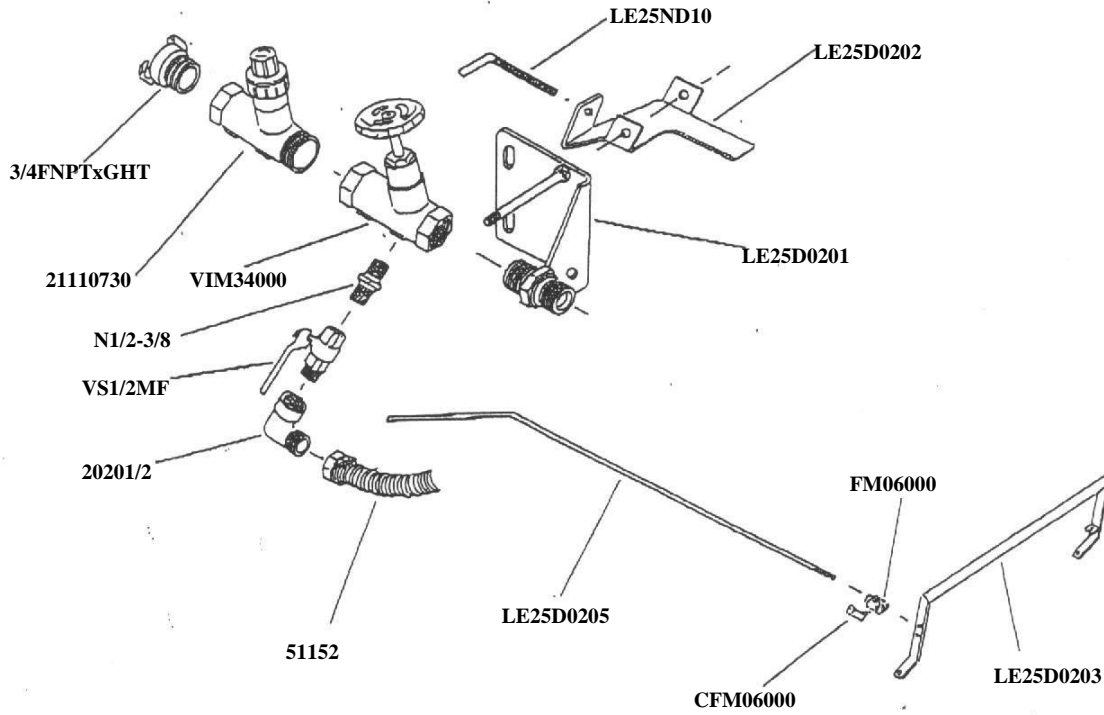

BigSprinkler.com/ReelGreen
DISTRIBUTOR, DEALER/SELLER, PURCHASER AGREEMENT

LIMITED WARRANTY AND REMEDY:

WARRANTY

BigSprinkler.com. as distributor, warrants to the original purchaser only of the ReelGreen Irrigation Equipment described in the face hereof as of the date of the original invoice, that the equipment is merchantable and free from defects in material and workmanship.

This warranty does not apply to certain component parts used on ReelGreen equipment. Warranty shall be provided by the original manufacturer of these components. Such components include, but are not limited to tires and tubes, boost pump motors, PTO drive shafts, valves, and batteries.

REMEDY

If BigSprinkler.com determines that the above warranty was breached with respect to any part or component provided by the manufacturer of ReelGreen equipment, (and if all conditions set forth below have been satisfied) then, BigSprinkler.com, will (at BigSprinkler.com's option) repair or provide purchaser replacement parts F.O.B. Yukon, OK. As follows:

All components of new ReelGreen system for 1 year from original equipment invoice, free of charge.
BigSprinkler.com will repair or provide replacement polyethylene tube for any tube BigSprinkler.com determines has failed, due to defects in workmanship or materials for 3 years from the date of original invoice, free of charge.

All remedies provided herein are for parts only, no labor or freight allowance for return parts is implied.

This warranty extends only to the original purchaser of ReelGreen equipment purchased from BigSprinkler.com

CONDITIONS TO ENFORCEABILITY AND CLAIMS:

Equipment has been maintained and operated within the guidelines outlined in ReelGreen owner's operation and maintenance manual.

Equipment warranty shall be considered void if any component or function of the equipment has been altered in any form other than what has been provided or intended by the original equipment manufacturer .

Any claim must be submitted on form provided by BigSprinkler.com in writing immediately and in no event longer than 20 days from occurrence.

Purchaser/Dealer must return all parts within 45 days of BigSprinkler.com's authorization date, that have been determined by BigSprinkler.com to be defective to the Purchaser/Dealer with Purchaser/Dealer being responsible for freight.

LIMITATIONS:

Neither BigSprinkler.com nor it's affiliates shall be liable for any incidental or consequential damages (including but not limited to, damages for injury to the person, property or lost turf, crops or profits) by reason of any defect in the equipment or its manufacture, design, or function.

BigSprinkler.com
09/09